

Vandalite

Vandalite is a surface mounted fluorescent luminaire that, as its name implies, is a tough, dust and watertight product for situations where semi-outdoor exposure and vandalism can be a problem. The Vandalite has an IP65 rating, being totally dustproof and waterproof. Its robust construction makes it virtually vandal-proof. The body is injection moulded, glass filled nylon for long life and added strength. The reflector is of pressed prepainted steel with integral gear and rota-lock lampholders for 1xTL5 14W lamp or with moulding and posts for 2xPL 18W or 1xPL 36W lamps.



Features and Benefits

- Dust, water and impact protection
- Optimum light distribution and performance
- Easy installation and maintenance

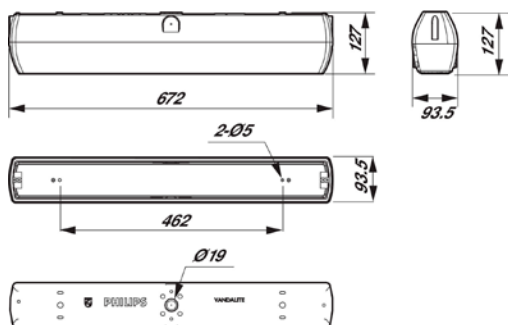

Product ID	L (mm)	W (mm)	H (mm)
TCW098 T5	672	93	126
TCW098 T8	672	93.5	127

Dimensions in mm (Nominal)

VANDALITE

Family Name	Vandalite	Installation	Screw mounted
Model	TCW098	IP rating	IP65
Watt	14W (T5), 18W/36W (T8)	Weight	2kg
Lamp Colour	N/A	Application	Residential, Industrial, Commercial
Colour Rendering Index (CRI)	N/A	Accessories	N/A
Flex and Plug	No		
Driver	High Frequency Ballast/Conventional		

COMMERCIAL CODE	I2NC	DESCRIPTION
TCW098I14T5CL	910403630084	TCW098 1xTL5 14W K HFS CL
TCW098I14T5OP	910403630085	TCW098 1xTL5 14W K HFS OP
FCW09824CFLOP	911400606880	FCW098 IX Tornado 24W K O