

# AFB 1841F A+ EX

12NC: 859991583140

GTIN (EAN) code: 8003437043598

Whirlpool

SENSING THE DIFFERENCE

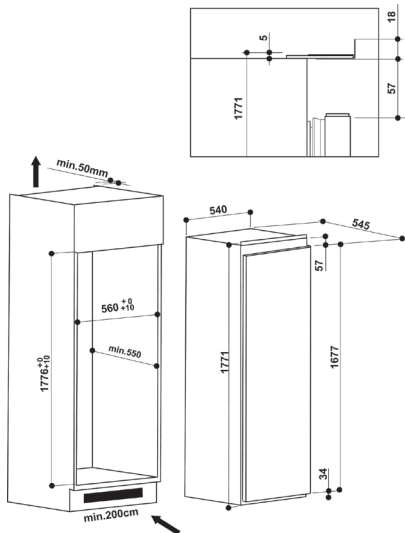

- Energy class A+
- Product dimensions (HxWxD): 1771x540x545 mm
- Total net capacity: 209 L
- Freezing capacity 19.00 kg/24 h
- 6th Sense FreezeControl
- No frost
- Fast freezing
- Fast freezing indicator light
- Temperature adjustable
- Eco Night
- Acoustic alarm
- Internal touch display
- Freezing system for freezer compartment: no frost
- Water Drainage System
- Fast Freezing Automatic Switch-off
- 7 drawers
- Reversible door

## Whirlpool integrated upright freezer: white color - AFB 1841F A+ EX

This Whirlpool integrated upright tall Freezer features: white color. No Frost, frost free technology, that reduces the humidity inside the freezer, effectively preventing ice build-up. FastFreezing technology, that freezes your food faster, to protect its taste, texture and nutritional values.



### Fast Freezing

Fast freezing. The Fast Freeze function sets the freezer temperature to 10 degrees colder than the lowest setting, to freeze food quickly and retain its nutritional values.



### Electronic control

Effortless control. This Whirlpool Freezer includes an intuitive electronic user interface, designed to provide you with the simplest, most satisfying user experience ever.



### Eco Night

Reduced energy costs. The EcoNight function optimises performance and reduces energy costs by running the defrosting cycles during low tariff hours, at night.



### 18M

This is a 180cm high built in Whirlpool Freezer.



### No frost system

No defrosting required. Total NoFrost technology reduces the humidity inside the freezer, preventing ice build-up.



### A+ energy efficiency

Outstanding energy efficiency. With its A+ energy rating, this Whirlpool Freezer will allow you to enjoy both ideal results and lower energy consumption.



### Interior light

Perfect illumination. This Whirlpool Freezer incorporates an internal light which ensures ideal visibility, so you will always find what you are looking for.



### Water drainage system

Defrost with ease. This Whirlpool Freezer incorporates a water drainage system which ensures effortless defrosting and cleaning.

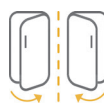

### Reversible Door

Reversible door hinges for added versatility to fit with your kitchen layout - choose to open to the left or the right.



### Alarms / Alerts

Blackouts? No problem. Blackout Alert will monitor the temperature inside your refrigerator. A red blinking light will inform you if the temperature reaches -8°.

# AFB 1841F A+ EX

12NC: 859991583140

GTIN (EAN) code: 8003437043598

Whirlpool

SENSING THE DIFFERENCE

## MAIN FEATURES

Product group	Freezer
Commercial code	AFB 1841F A+ EX
GTIN (EAN) code	8003437043598
Construction type	Built-in
Installation type	Built-in
Type of control	Electronic
Main colour of product	White
Electrical connection rating (W)	130
Current (A)	13
Voltage (V)	220-240
Frequency (Hz)	50
Length of Electrical Supply Cord (cm)	200
Plug type	UK
Total unit net capacity (l)	209
Height of the product	1771
Width of the product	540
Depth of the product	545
Maximum adjustability feet	0
Net weight (kg)	57.0
Gross weight (kg)	59.0
Door hinge	-

## TECHNICAL FEATURES

Defrost process	Frost-free
Fast freezing function	Yes
Refrigerator section with thaw water drainage system	Yes
Number of drawers/baskets	8
Lockable door	No
Thermometer freezer section	N/A
Interior light	-

## PERFORMANCES

Energy efficiency class - NEW (2010/30/EU)	A+
Freezing capacity (kg/24h) - NEW (2010/30/EU)	19.00
Temperature rise time (h)	23
Climate class	SN-T
Frost free system	Freezer
Freezer Net capacity (l) - NEW (2010/30/EU)	209

ENERGIA - ЕНЕРГИЈА  
ΕΝΕΡΓΕΙΑ - ENERGIJA  
ENERGY - ENERGIE - ENERGI

WHIRLPOOL  
AFB 1841F A+ EX

A+++  
A++  
A+  
A  
B  
C  
D

A+

307  
kWh/annum

ENERGIA - ЕНЕРГИЈА  
ΕΝΕΡΓΕΙΑ - ENERGIJA  
ENERGY - ENERGIE - ENERGI

1L

- L

209L

39 dB

2010/1060