

GMA 9522/IX

12NC: 859991030220

GTIN (EAN) code: 8003437829819

Whirlpool

SENSING THE DIFFERENCE



Whirlpool gas hob: 5 gas burners - GMA 9522/IX

This Whirlpool gas Hob features: wok cooking adapter, specifically tailored for wok use.



Power Burner 5gas (PB)

Power cooking. This Whirlpool Hob features 5 Power burners to provide extra heat and speed up boiling, frying and steaming, while ensuring maximum energy efficiency.



Wok Cooking

This hob comes with a wok burner and is perfect for stir fries and all fast cooking requirements.



Speed to Boil

Enjoy faster boiling. Our innovative technology, by effectively harnessing the energy of the flames, ensures more heat is delivered directly to your pots and pans allowing you to enjoy ideal cooking results, sooner.



Stainless Steel

For the stylish modern look in your kitchen.



Front Controls

Complete control over your cooking. Easily accessible and genuinely intuitive, the controls are conveniently positioned on the front panel of your hob, providing a frictionless cooking experience.

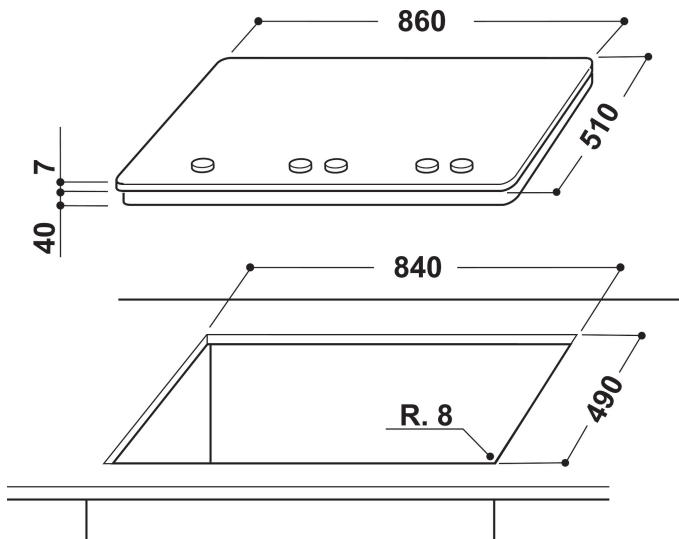

- Cast Iron Pan Supports
- Electromagnetic safety device for each burner
- Wok grid adapter
- Silver painted knobs
- 3 Fusion Aphrodite 2 Cast Iron grids
- Front controls
- 90 cm hob
- Mechanical control
- Ignition type: knob
- 5 Burners
- 5 burners: 1 Power burner 5000 W burner, 1 Semirapid 1650 W burner, 1 Semirapid 3000 W burner, 1 Rapid 1000 W burner, and 1 Auxiliary 1650 W burner.
- Supply cord included
- Dimensions HxWxD: 41x860x510 mm
- Niche dimensions HxWxD: 41x840x490 mm
- Voltage: 220-240 V

GMA 9522/IX

12NC: 859991030220

GTIN (EAN) code: 8003437829819

Whirlpool

SENSING THE DIFFERENCE

MAIN FEATURES

Product group	Hob
Construction type	Built-in
Type of control	Mechanical
Type of control settings	-
Number of gas burners	5
Number of electric cooking zones	0
Number of electric plates	0
Number of radiant plates	0
Number of halogen plates	0
Number of induction plates	0
Number of electric warming zones	0
Location of control panel	Front
Basic surface material	Inox
Main colour of product	Inox
Electrical connection rating (W)	0
Gas connection rating (W)	12300
Current (A)	0,2
Voltage (V)	220-240
Frequency (Hz)	50/60
Length of Electrical Supply Cord (cm)	110
Plug type	No
Gas connection	Cilindric
Width of the product	860
Height of the product	41
Depth of the product	510
Minimum niche height	41
Minimum niche width	840
Niche depth	490
Net weight (kg)	17.8
Automatic programmes	No

TECHNICAL FEATURES

Power on indicator	No
Number of indicators	0
Type of regulation	Temperature regulated
Type of lid	Without
Residual heat indicator	Without
Main on/off switch	No
Safety device	-
Timer	No

PERFORMANCES

Energy input	Gas
--------------	-----