

MXA K7F IX

12NC: 859991570450

GTIN (EAN) code: 8003437237614

Whirlpool

SENSING THE DIFFERENCE



Whirlpool built in electric oven: inox color - MXA K7F IX

This Whirlpool built in Oven features: advanced electric technology allowing you to cook dishes saving energy.



Multifunction 8

Multiple cooking methods. The Multifunction 8 feature offers flexible cooking options, to ensure perfect results, whatever the recipe.



Easy to clean

Easy to clean. To clean your oven, simply use warm water and a soft cloth, no need to use harsh chemicals or cleaners.



Absolute aesthetic

The Absolute collection. Admire the beauty of performance. With a futuristic design and unparalleled performance, the Absolute collection is designed for modern, high-tech kitchens. Equipped with innovative 6TH SENSE technology, Absolute ovens can be set in three simple steps for perfect results. Maximum flexibility and ease of use with a distinctive look and original finishes.



Electronic control

Electronic temperature control.



XXL cavity

All the space you need. The XXL cavity in your oven has a capacity of 75 litres with 5 different shelf positions available.

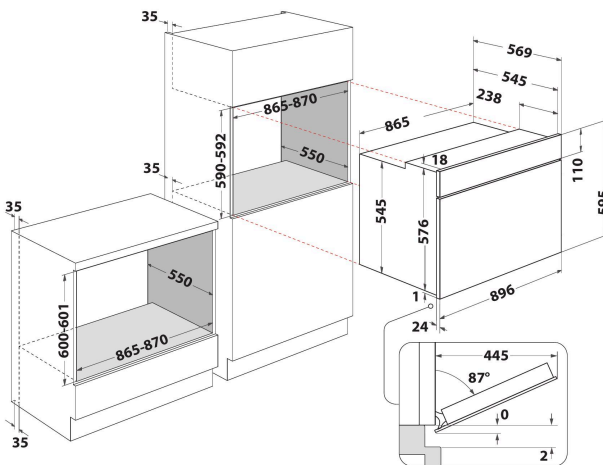

- Energy class B
- Cavity 101 L
- Forced Air Fan Cooking
- Turbo Fan
- Grill
- Easy Clean Enamel Interior
- Turbo grill function
- Maxi cooking
- Pastry function
- Conventional Cooking
- Metal handle
- Door Glasses Number: 3
- Timer
- Grill 3250 W
- 2 Grids
- 1 Tray
- Motorized Turn Spit

MXA K7F IX

12NC: 859991570450

GTIN (EAN) code: 8003437237614

Whirlpool

SENSING THE DIFFERENCE

MAIN FEATURES

Product group	Oven
Commercial code	MXA K7F IX
Main colour of product	Inox
Construction type	Built-in
Type of control	Electronic
Type of control settings	-
Are any hobs controls integrated?	No
Which kind of hobs can be controlled?	-
Automatic programmes	No
Current (A)	15,6
Voltage (V)	220-240
Frequency (Hz)	50/60
Length of Electrical Supply Cord (cm)	150
Plug type	No
Depth with open door 90 degree (mm)	-
Height of the product	595
Width of the product	896
Depth of the product	565
Minimum niche height	0
Minimum niche width	0
Niche depth	0
Net weight (kg)	53
Usable volume (of cavity)	101
Integrated Cleaning system	Easy to clean enamel
Grids of the cavity	2
Trays	1

TECHNICAL FEATURES

Timer	Yes
Time control	Electronic
Time-setting options	Start and Stop
Safety device	-
Interior light	Yes
Number of interior lights of the cavity	1
Position of interior lights of the cavity	Rear right
Oven guides of the cavity	N/A
Probe of the cavity	No

PERFORMANCES

Energy input	Electric
Type of energy of the cavity	Electricity
Energy efficiency class - NEW (2010/30/EU)	B
Energy consumption per cycle conventional - NEW (2010/30/EU)	1.16
Energy consumption per cycle forced air convection - NEW (2010/30/EU)	0

ENERG Y UA
енергия · ενεργεια IE 1A

WHIRLPOOL MXA K7F IX

A+++
A++
A+
A
B
C
D

B

101 kWh/cycle*

0 kWh/cycle*

* ημερησια - cyklus - parhion - zyklos - nopolynajusa - ciclo - tsükkel - ohjelma - ciklus - cikls - ciklu - cyclus - cykl - ciclu - program - cykel

65/2014